

Stationary parts

www.depac.at



Table of contents

DS1, DS2, DS3, DS4	S. 5-8
DS6, DS7, DS8, DS9	S. 9-11

DEPAC stationary parts – extremely versatile!

A component mechanical seal consists of the individual parts of the rotary unit, the stationary part and the stationary retainer, also known as the „gland“. In the spare parts market, the units in use at the end consumers have the most diverse retainers and dimensions. In order to cater for this situation and to offer the operator an alternative to his existing parts, DEPAC offers a large selection of different stationary parts. The selection of the ideal mechanical seal must accordingly be accompanied by the selection of the correct stationary part. The alternative to this, however, is the selection of the ideal stationary part with the possible use of a new gland or an adapter part, which can be seen in the separate data sheet „Glands and adapter parts“.

Notes

To check the specified installation lengths, e.g. L1KU from DIN 24960 / EN12756, the length dimensions of the selected mechanical seal should be added to the length dimensions of the stationary part. The stationary parts are supplied with O-rings or V-rings. Standard materials for O-rings and V-rings are EPDM or FKM. Other dimensions and materials are available on request or enquiry.

Stationary parts

Stationary parts

Technical specifications

Dimensions

Shaft diameter: 10 – 160 mm*
 3/8" – 4" **
 Special sizes on request

* DIN 24960 / EN12756 only up to a shaft diameter of 100 mm
 ** For mechanical seals with imperial dimensions, the corresponding metric stationary parts according to the dimension table can be used.

Bill of materials

Designation		Description	Stationary parts								
DIN 24960 / EN12756	DEPAC		DS1	DS2	DS3	DS4	DS6	DS7	DS8	DS9	

Sliding materials, point 1/2

B	CA	Carbon, impregnated with synthetic resin			●					
V	CE	Ceramic (AL oxide)				○	○			
Q1	SSIC	Silicon carbide, SiC, pressurelessly sintered	●	●		○	○	●	●	●
Q2	SC	Silicon carbide, SiC-Si, reaction-bonded	●	●		●	●	●	●	●
U2	TC	Tungsten carbide, Ni-bonded	●	●		○	○	○	●	●

Auxiliary seals, point 3

E	EPDM	Ethylene propylene diene monomer rubber	●	●	●	●	●		●	●
K	FFKM	Perfluoroelastomers (Kalrez®, Chemraz®)	○	○	○				○	○
M5	FEP umm. FKM	FKM coated with fluorinated ethylene-propylene	○	○	○					○
P	NBR	Nitrile butadiene rubber	●	●	●	○	○		●	●
S	Silikon	Silicone rubber	○	○	○				○	○
T	PTFE	Polytetrafluoroethylene	○	○	○					○
V	FKM	Fluoroelastomer (Viton®)	●	●	●	●	●		●	●
X	FEPM	Hydrated nitrile butadiene rubber (HNBR) Tetrafluoropropylene rubber (Aflas®)	○	○	○				○	○
-	C-4300	Klingsil® C-4300						●		

● Standard ○ On request Special materials on request

DS1
EN 12756

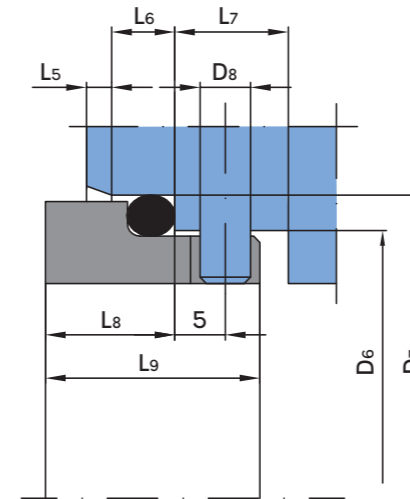

DS2
EN 12756

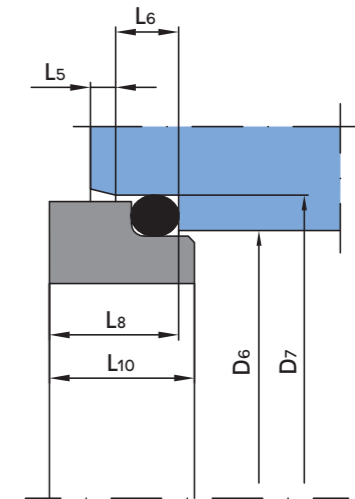

DS3
EN 12756

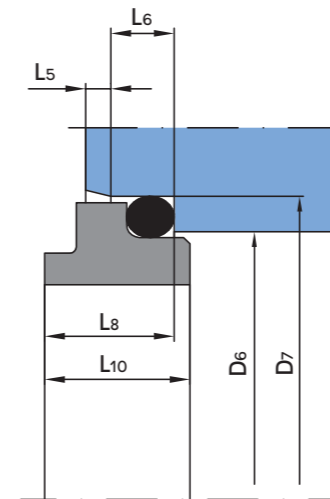

DS4
EN 12756

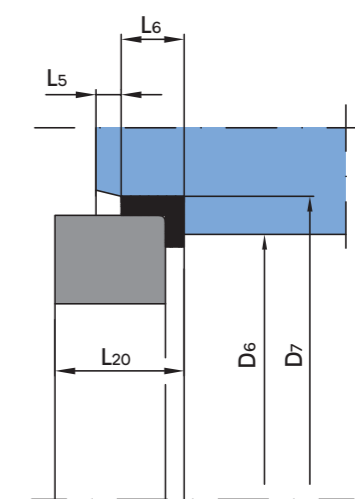

Dimension table Ø 10 – 33 mm | 3/8 – 1 1/4 inches

												DASH no. O-ring dimension		
Shaft-Ø mm*	Shaft-Ø Inch	D6	D7	D8	L5	L6	L7	L8	L9	L10	L20	DS1	DS2	DS3
10	3/8	17	21	3	1,5	4	8,5	7,8	15	10	6,6	114	114	114
12		19	23	3	1,5	4	8,5	7,8	15	10	6,6	115	115	115
14	1/2	21	25	3	1,5	4	8,5	7,8	15	10	6,6	117	117	117
16	5/8	23	27	3	1,5	4	8,5	7,8	15	10	6,6	118	118	118
18		27	33	3	2	5	9	10,2	17	11,5	7,5	214	214	214
20	3/4	29	35	3	2	5	9	10,2	17	11,5	7,5	216	216	216
22	7/8	31	37	3	2	5	9	10,2	17	11,5	7,5	217	217	217
24	15/16	33	39	3	2	5	9	10,2	17	11,5	7,5	218	218	218
25		34	40	3	2	5	9	10,2	17	11,5	7,5	219	219	219
28		37	43	3	2	5	9	10,2	17	11,5	7,5	221	221	221
30		39	45	3	2	5	9	10,2	17	11,5	7,5	222	222	222
32	1 1/4	42	48	3	2	5	9	10,2	17	11,5	7,5	223	223	223
33		42	48	3	2	5	9	10,2	17	11,5	7,5	223	223	223

Stationary parts

Stationary parts

DS1
EN 12756

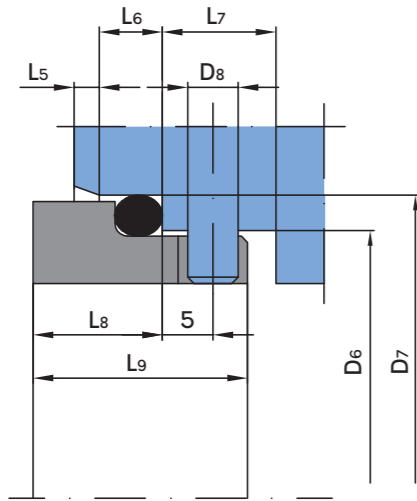

DS2
EN 12756

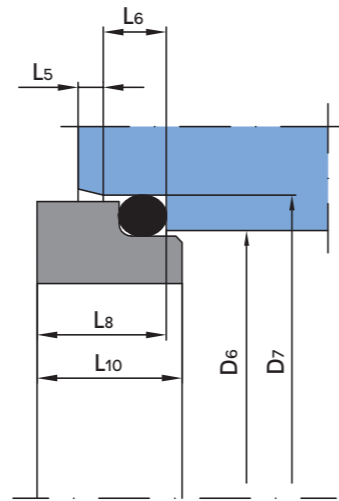

DS1
EN 12756

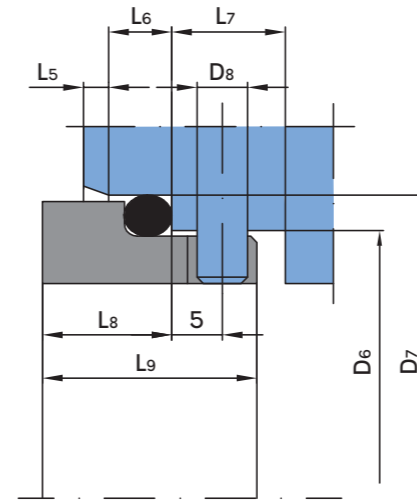

DS2
EN 12756

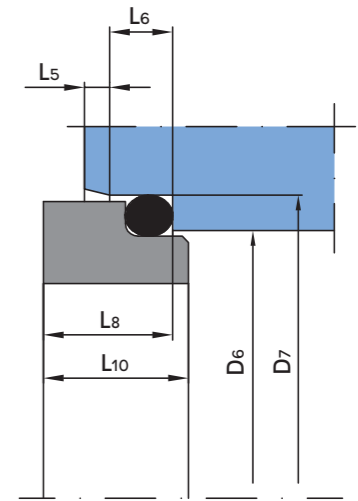

DS3
EN 12756

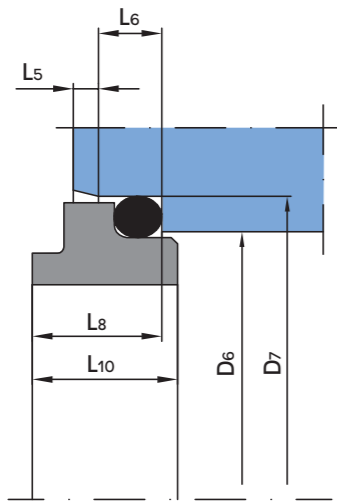

DS4
EN 12756

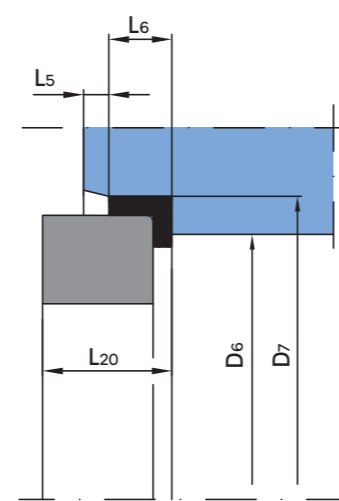

DS3
EN 12756

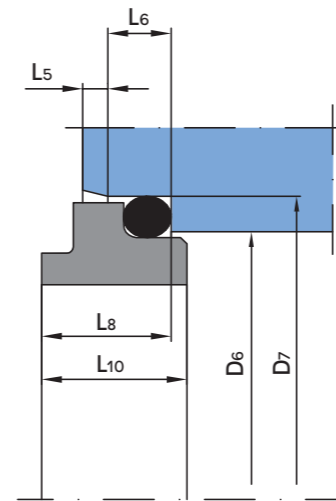

DS4
EN 12756

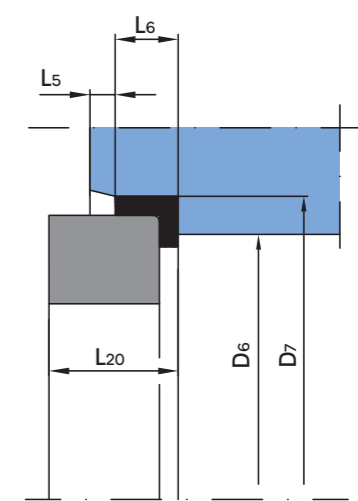

Dimension table Ø 35 – 70 mm | 1 3/8 – 2 3/4 inches

Dimension table Ø 75 – 100 mm | 3 1/8 – 4 inches

Shaft-Ø mm*	Shaft-Ø inches	DASH no. O-ring dimension												
		D6	D7	D8	L5	L6	L7	L8	L9	L10	L20	DS1	DS2	DS3
35	1 3/8	44	50	3	2	5	9	10,2	17	11,5	7,5	223	223	223
38	1 1/2	49	56	4	2	6	9	11,7	19	12	9	48 × 4,5	48 × 4,5	48 × 4,5
40		51	58	4	2	6	9	11,7	19	12	9	50 × 4,5	50 × 4,5	50 × 4,5
43		54	61	4	2	6	9	11,7	19	12	9	51 × 4,5	51 × 4,5	51 × 4,5
45	1 3/4	56	63	4	2	6	9	11,7	19	12	9	56 × 4,5	56 × 4,5	56 × 4,5
48	1 7/8	59	66	4	2	6	9	11,7	19	12	9	57 × 4,5	57 × 4,5	57 × 4,5
50		62	70	4	2,5	6	9	13,7	21	13,5	9,5	61 × 5,0	61 × 5,0	61 × 5,0
53		65	73	4	2,5	6	9	13,7	21	13,5	11	64 × 5,0	64 × 5,0	64 × 5,0
55	2 1/8	67	75	4	2,5	6	9	13,7	21	13,5	11	66 × 5,0	66 × 5,0	66 × 5,0
60	2 3/8	72	80	4	2,5	6	9	13,7	21	13,5	11	70 × 5,0	70 × 5,0	70 × 5,0
63		75	83	4	2,5	6	9	13,7	21	13,5	11	73 × 5,0	73 × 5,0	73 × 5,0
65		77	85	4	2,5	6	9	13,7	21	13,5	11	75 × 5,0	75 × 5,0	75 × 5,0
70	2 3/4	83	92	4	2,5	7	9	15,6	23	15	11,3	339	339	339

Shaft-Ø mm*	Shaft-Ø inches	DASH no. O-ring dimension												
		D6	D7	D8	L5	L6	L7	L8	L9	L10	L20	DS1	DS2	DS3
75		88	97	4	2,5	7	9	15,6	23	15	11,3	340	340	340
80	3 1/8	95	105	4	3	7	9	16,3	23,5	17	12	95 × 6,0	95 × 6,0	95 × 6,0
85	3 3/8	100	110	4	3	7	9	16,3	23,5	17	14	96 × 6,0	96 × 6,0	96 × 6,0
90	3 1/2	105	115	4	3	7	9	16,3	23,5	17	14	104 × 6,0	104 × 6,0	104 × 6,0
95	3 7/8	110	120	4	3	7	9	16,3	23,5	17	14	108 × 6,0	108 × 6,0	108 × 6,0
100	4	115	125	4	3	7	9	16,3	23,5	17	14	114 × 6,0	114 × 6,0	114 × 6,0

* EN12756 only up to a shaft diameter of 100 mm

Stationary parts

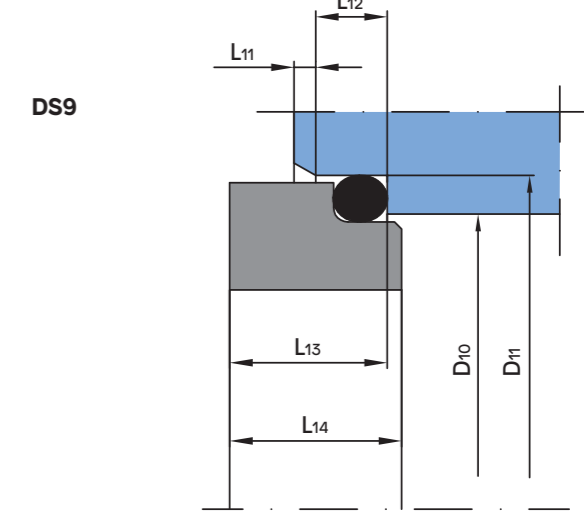
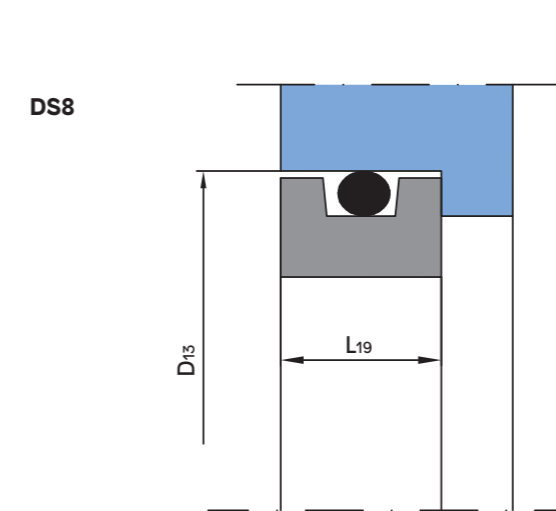
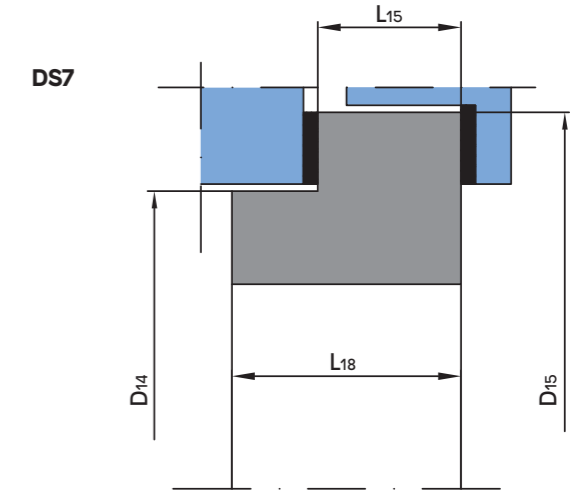
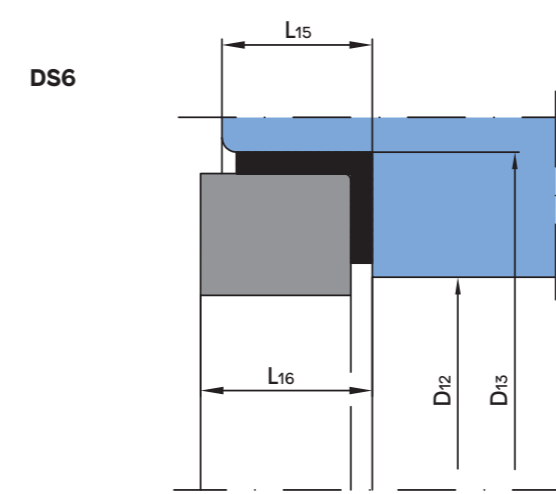
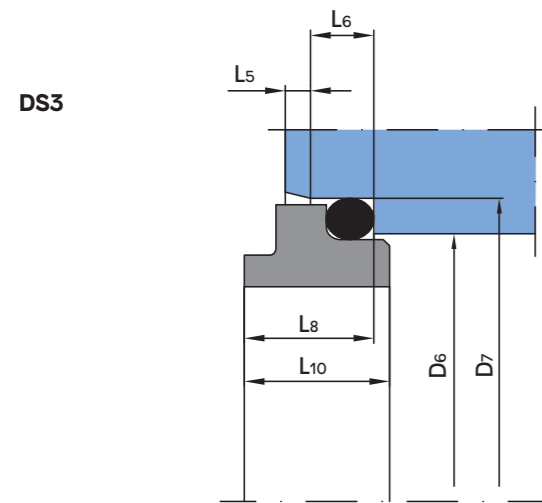
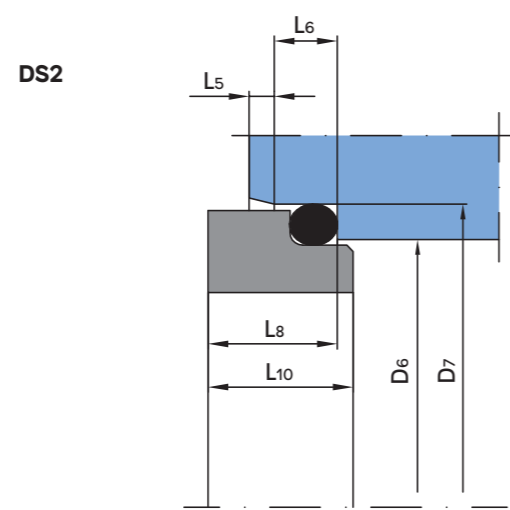
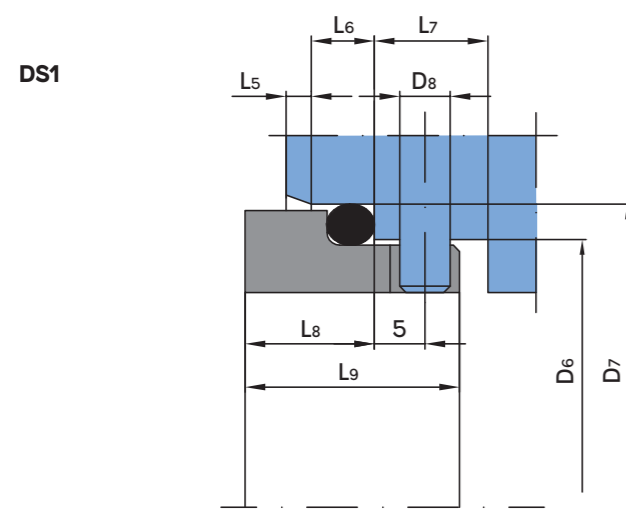

Dimension table Ø 105 – 160 mm

Shaft-Ø	DASH no. O-ring dimension										
	D6	D7	D8	L5	L6	L7	L8	L9	DS1	DS2	DS3
105	121,5	131	4	3	7	9	16	23,5	119,3 × 5,7	119,3 × 5,8	119,3 × 5,9
110	126,5	136	4	3	7	9	16	23,5	124,3 × 5,7	124,3 × 5,8	124,3 × 5,9
115	131,5	141	4	3	7	9	16	23,5	129,3 × 5,7	129,3 × 5,8	129,3 × 5,9
120	140,5	150	4	3	7	9	16	23,5	139,3 × 5,7	139,3 × 5,8	139,3 × 5,9
125	145,5	155	4	3	7	9	16	23,5	144,3 × 5,7	144,3 × 5,8	144,3 × 5,9
130	150,5	160	4	3	7	9	16	23,5	149,3 × 5,7	149,3 × 5,7	149,3 × 5,7
133	153,5	163	4	3	7	9	16	23,5	149,3 × 5,7	149,3 × 5,7	149,3 × 5,7
135	155,5	165	4	3	7	9	16	23,5	154,3 × 5,7	154,3 × 5,8	154,3 × 5,9
140	160,5	170	4	3	7	9	16	23,5	159,3 × 5,7	159,3 × 5,8	159,3 × 5,9
145	165,5	175	4	3	7	9	16	23,5	164,3 × 5,7	164,3 × 5,8	164,3 × 5,9
150	170,5	180	4	3	7	9	16	23,5	169,3 × 5,7	169,3 × 5,8	169,3 × 5,9
155	175,5	185	4	3	7	9	16	23,5	174,3 × 5,7	174,3 × 5,8	174,3 × 5,9
160	180,5	190	4	3	7	9	16	23,5	179,3 × 5,7	179,3 × 5,8	179,3 × 5,9

Dimension table Ø 10 – 30 mm

Shaft-Ø	DASH no. O-ring dimension																
	D10	D11	D12	D13	D14	D15	L11	L12	L13	L14	L15	L16	L17	L18	L19	L13	L14
10	15,5	19,2	11	24,60	-	-	1,2	3,8	6,6	7,5	7,5	9	-	-	9	209	113
12	17,5	21,6	13,5	27,80	-	-	1,2	3,8	5,6	6,5	7,5	9	-	-	9	211	115
14	20,5	24,6	17	30,95	-	-	1,2	3,8	5,6	6,5	9	10,5	-	-	11,2	214	116
15	20,5	24,6	17	30,95	-	-	1,2	3,8	6,6	7,5	9	10,5	-	-	11,2	214	116
16	22	28	17	30,95	-	-	1,5	5	7,5	8,5	9	10,5	-	-	11,2	214	211
18	24	30	20	34,15	32	46	1,5	5	8	9	9	10,5	10	16	11,2	215	213
19	-	-	20	34,15	-	-	-	-	-	-	9	10,5	-	-	11,2	-	-
20	29,5	35	21,5	35,70	36	48	1,5	5	7,5	8,5	9	10,5	10	16	11,2	217	216
22	29,5	35	23	37,30	-	-	1,5	5	7,5	8,5	9	10,5	-	-	11,2	218	216
24	32	38	26,5	40,50	41	53	1,5	5	7,5	8,5	9	10,5	10	16	11,2	220	218
25	32	38	26,5	40,50	41	53	1,5	5	7,5	8,5	9	10,5	10	16	11,2	220	218
28	36	42	29,5	47,65	44	56	1,5	5	9	10	10,5	12	10	16	11,2	223	220
30	39,2	45	32,5	50,80	44	56	1,5	5	10,5	11,5	10,5	12	10	16	11,2	224	222

Stationary parts

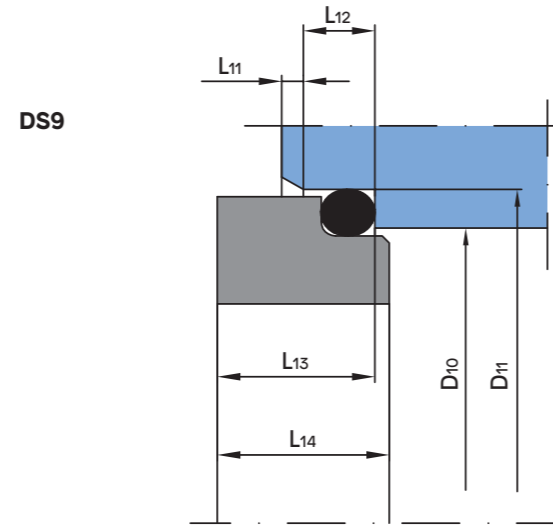
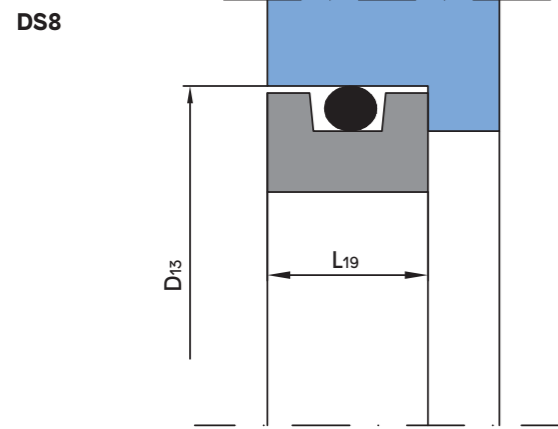
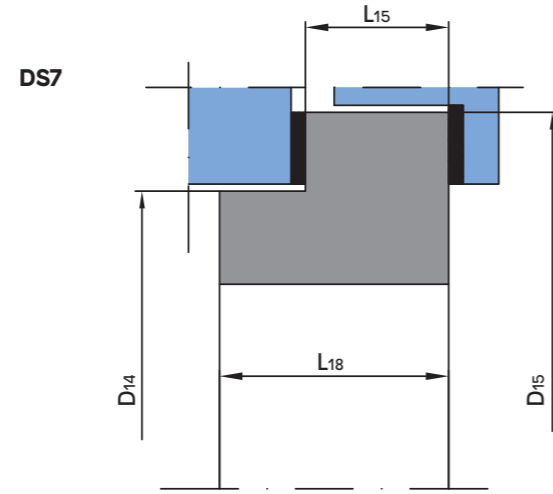
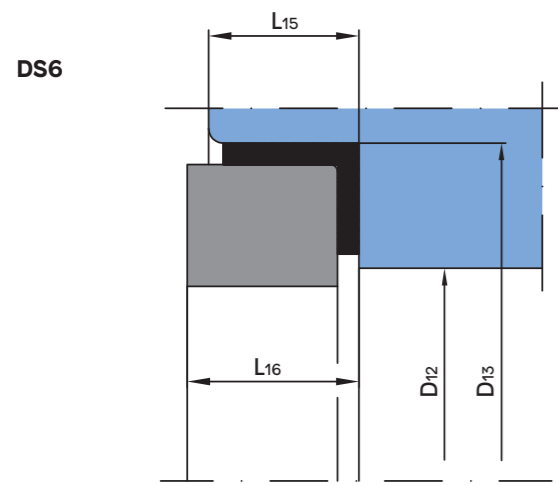

Dimension table Ø 32 – 63 mm

Shaft-Ø	DASH Nr. O-Ringe																
	D10	D11	D12	D13	D14	D15	L11	L12	L13	L14	L15	L16	L17	L18	L19	L13	L14
32	42,2	48	32,5	50,80	49	59	1,5	5	10,5	11,5	10,5	12	10	16	11,2	224	223
33	44,2	50	36,5	54,00	49	59	1,5	5	11	12	10,5	12	10	16	11,2	225	223
35	46,2	52	36,5	54,00	51	61	1,5	5	11	12	10,5	12	10	16	11,2	225	224
38	49,2	55	39,5	57,15	58	69	1,5	5	10,3	11,3	10,5	12	10	16	11,2	226	225
40	52,2	58	42,5	60,35	60	72	1,5	5	10,8	11,8	10,5	12	10	16	12,7	227	226
43	53,3	62	46	63,50	63	78	2	6	12	13,2	10,5	12	10	16	12,7	228	329
45	55,3	64	46	63,50	65	78	2	6	11,6	12,8	10,5	12	10	16	12,7	228	330
48	59,7	68,4	49	66,70	66	82	2	6	11,6	12,8	10,5	12	10	16	12,7	229	331
50	60,8	69,3	52	69,85	70	82	2	6	11,6	12,8	12	13,5	10	16	12,7	230	332
53	63,8	72,3	55,5	73,05	75	94	2	6	12,3	13,5	12	13,5	10	16	14,3	231	333
55	66,5	75,4	58,5	76,20	75	94	2	6	13,3	14,5	12	13,5	10	16	14,3	232	334
60	71,5	80,4	61,5	79,40	85	98	2	6	13,3	14,5	12	13,5	10	16	14,3	233	335
63	74,5	83,4	65	82,55	87	104	2	6	13,3	14,5	12	13,5	10	16	15,9	234	336

Stationary parts

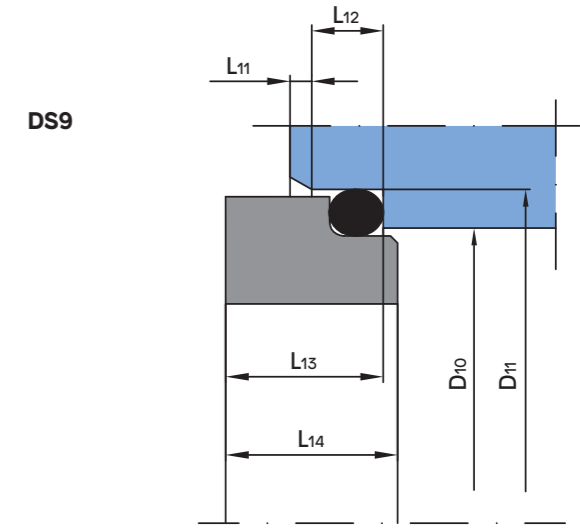
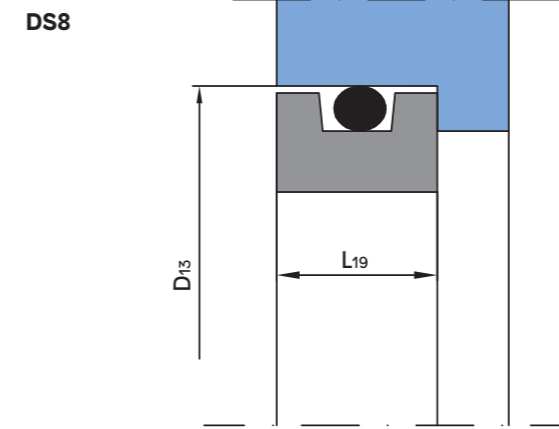
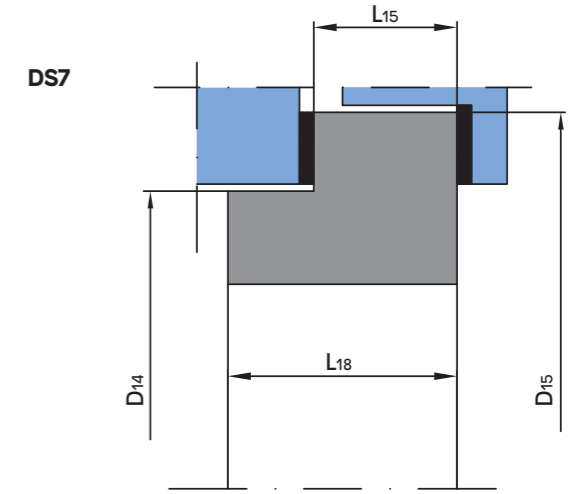
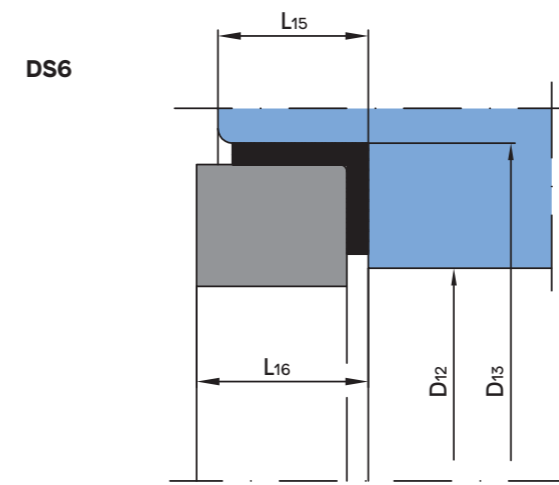

Dimension table Ø 65 – 100 mm

Shaft-Ø	DASH Nr. O-Ringe																
	D10	D11	D12	D13	D14	D15	L11	L12	L13	L14	L15	L16	L17	L18	L19	L13	L14
65	76,5	85,4	68	92,10	90	107	2	6	13	14,2	14,5	16	10	16	15,9	237	337
70	83	92	71	95,25	91	111	2	6	13	14,2	14,5	16	19	25	15,9	238	339
75	90,2	99	77,5	101,60	94	114	2	6	14	15,2	14,5	16	19	25	15,9	240	341
80	95,2	104	84	114,30	98	116	2	6	15	16,2	18,5	20	19	25	19,9	244	343
85	100,2	109	87	117,50	104	124	2	6	14,8	16	18,5	20	19	25	19,9	245	344
90	105,2	114	93,5	123,85	110	130	2	6	14,8	16	18,5	20	19	25	19,9	247	346
95	111,6	120,3	96,5	127,00	114	133	2	6	15,8	17	18,5	20	19	25	19,9	248	348
100	114,5	123,3	103	133,35	123	143	2	6	15,8	17	18,5	20	19	25	19,9	250	349



Mechanical seals
Packings
Hydraulic seals
Workshop
Comtec

DEPAC Anstalt
Wirtschaftspark 44, FL-9492 Eschen
T +423 373 9700, F +423 373 9719
office@depac-fl.com, www.depac.at

Your authorized DEPAC dealer:

E200836