

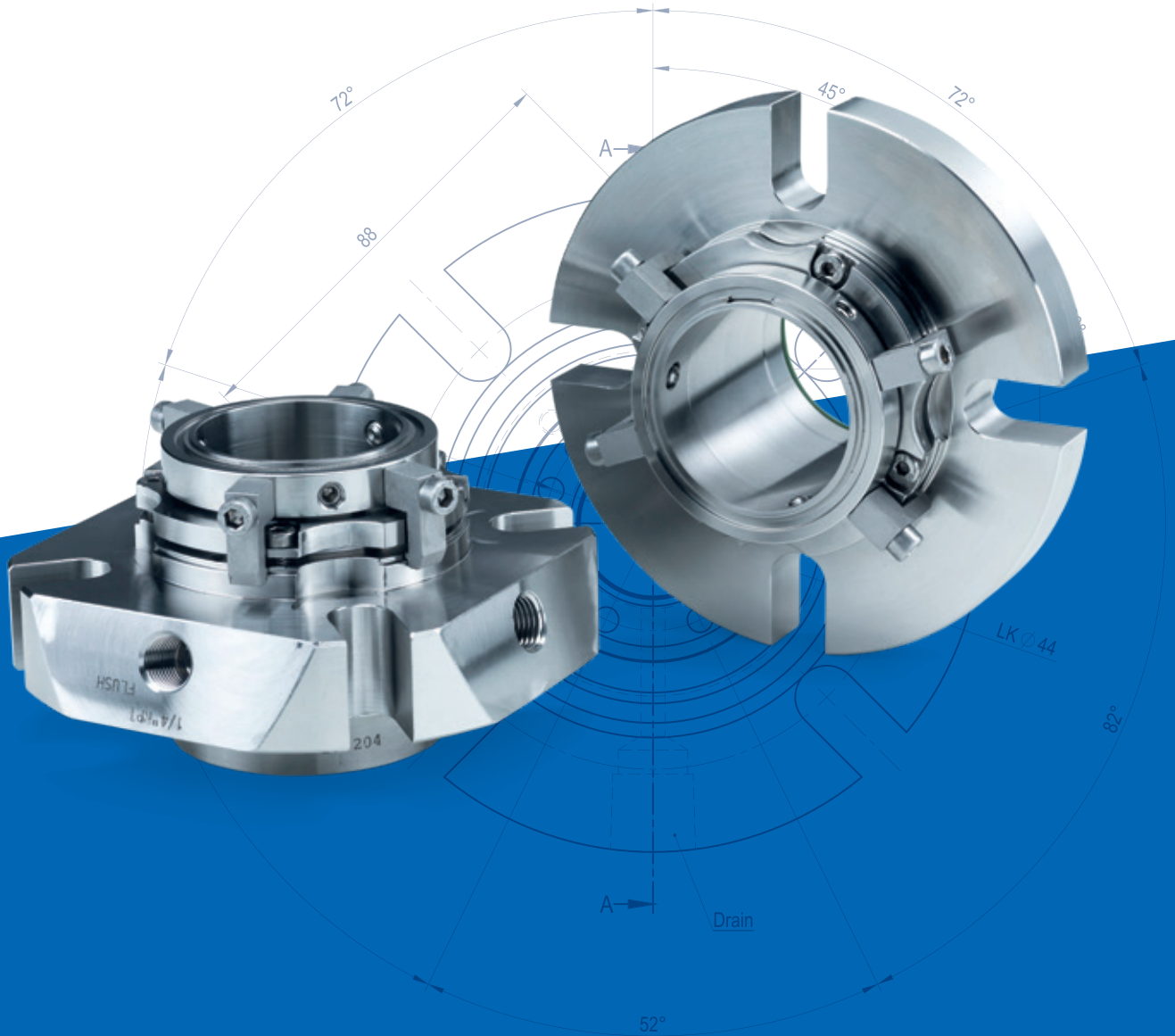

Types: 270P, 301P



Safety seals

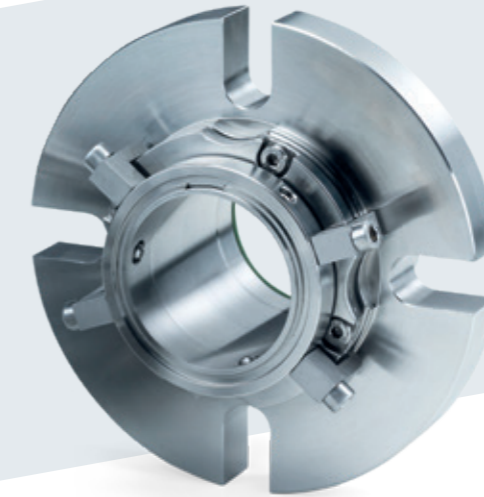

Table of contents

Type 270P	S. 3-8
Type 301P	S. 9-17

No mechanical seal lasts forever. Even with double seals, no manufacturer can guarantee that the second seal face pair will seal after the first has failed. The „Disaster Bushings“ demanded by the oil industry (API) also offer no protection in case of a leakage. The DEPAC type 270P, conversely, guarantees a high level of process reliability, because in the case of seal damage the integrated packing is simply adjusted to a minimum leakage rate and the mechanical seal can thus remain in service until the next planned standstill. The DEPAC type 270P is the new standard in cartridge-mounted mechanical seals, since expensive production losses and unplanned emergency assignments of fitters can be prevented.

Advantages

- Adjustable safety seal
- Stationary design principle
- Ideal for conversions from gland packings to mechanical seals
- Extremely well suited for standardisations
- Cartridge-mounted
- Pressure balanced
- Independent of the direction of rotation
- Multi-springs made of Hastelloy C
- Springs outside the medium
- Vibration-damped rotating face

Safety seal Type 270P

Safety seal Type 270P

Technical specifications

Area of application*

Pressure:	700 mmHg to 28 bar
Temperature:	depending on elastomer
Sliding speed:	up to 35 m/s
Shaft movements:	axial $\pm 1,0$ mm radial $\pm 0,5$ mm

* The maximum specifications for temperature, pressure and sliding speed apply in each case to independent higher operating conditions. However, this does not mean that the seal will function with all extreme conditions at the same time. If in doubt contact DEPAC.

Dimensions

Shaft diameter:	24 – 100 mm 1" – 4" Special sizes on request
-----------------	--

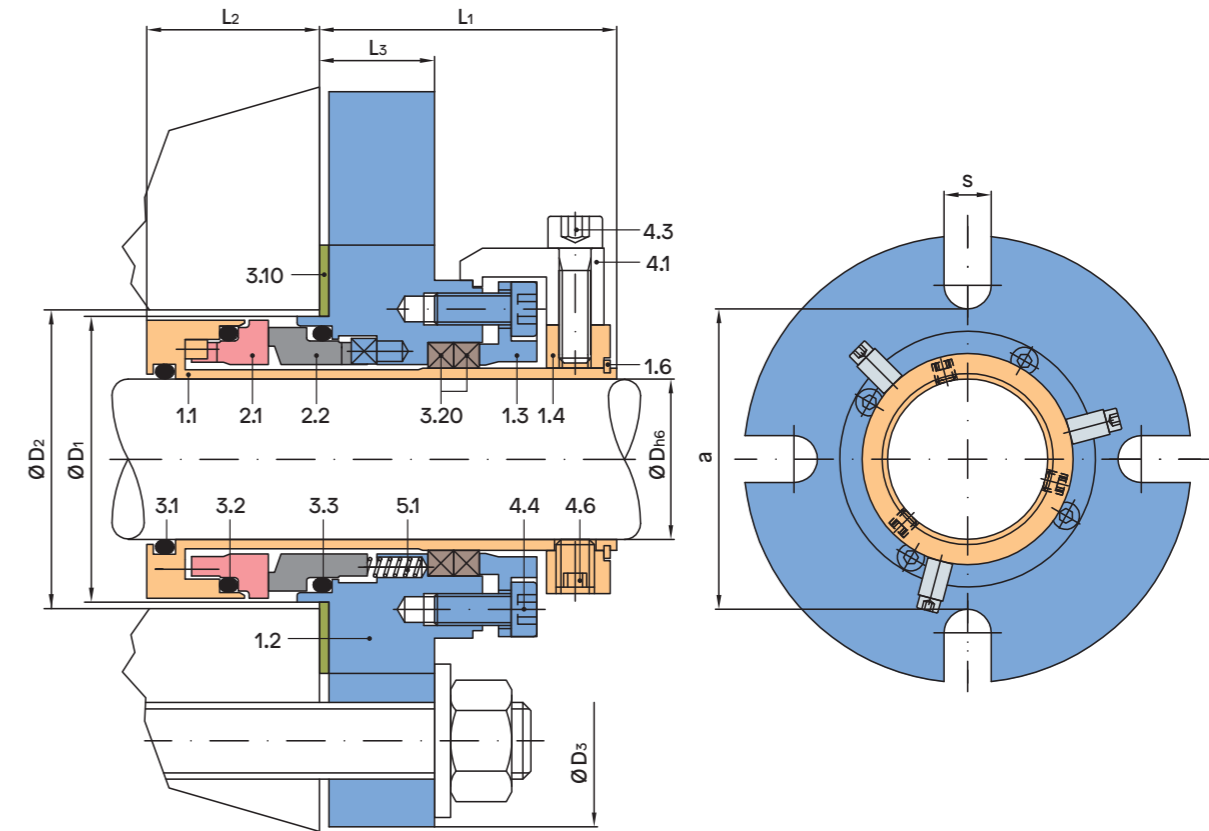

Bill of materials

Item	Description	Material
1.1	Sleeve	1.4571
1.2	Gland	1.4571
1.3	Packing gland	1.4571
1.4	Adjusting ring	1.4571
1.6	Circlip	1.4310
2.1	Dynamic seal face	SC/SSIC/TC
2.2	Stationary seal face	CA/SC/SSIC/TC
3.1, 3.2, 3.3	O-ring	FKM, EPDM, Kalrez®, PTFE,...
3.10	Flat gasket	Klingsil® C-4300
3.20	Integrated safety packing	Graphit - PTFE Packung DEPAC Type 730
4.1	Centering piece	Al
4.3	Socket screw	A2
4.4	Socket screw	A2
4.6	Threaded pin	A4
5.1	Spring	2.4610

Other materials on request!

Dimension table $\varnothing 24 - 50$ mm

Dh6	D1	D2 min.	D2 max.	D3	L1	L2	L3	a	s	O-rings DASH no.		
										3.1	3.2	3.3
24	44,7	46,7	54	104	45	28,5	19	62	12,5	120	127	127
25	44,7	46,7	54	104	45	28,5	19	62	12,5	120	127	127
28	47,7	49,7	54	104	45	28,5	19	62	12,5	122	129	129
30	49,7	51,7	59	104	45	28,5	19	67	12,5	123	130	130
32	50,9	52,9	59	104	45	28,5	19	67	12,5	124	131	131
33	50,9	52,9	59	104	45	28,5	19	67	12,5	125	131	131
35	54,7	56,7	62	115	45	28,5	19	70	12,5	126	133	133
38	57,7	59,7	67	125	45	28,5	19	75	14,7	128	136	136
40	59,7	61,7	67	125	45	28,5	19	75	14,7	130	137	137
42	61,7	63,7	72	133	45	28,5	19	80	14,7	131	138	138
43	62,7	64,7	72	133	45	28,5	19	80	14,7	132	138	138
45	64,7	66,7	74	140	45	28,5	19	82	14,7	133	140	140
48	67,7	69,7	74	140	45	28,5	19	82	14,7	135	142	142
50	69,7	71,7	79	140	45	28,5	19	87	14,7	136	143	143

Safety seal Type 270P

Safety seal Type 270P

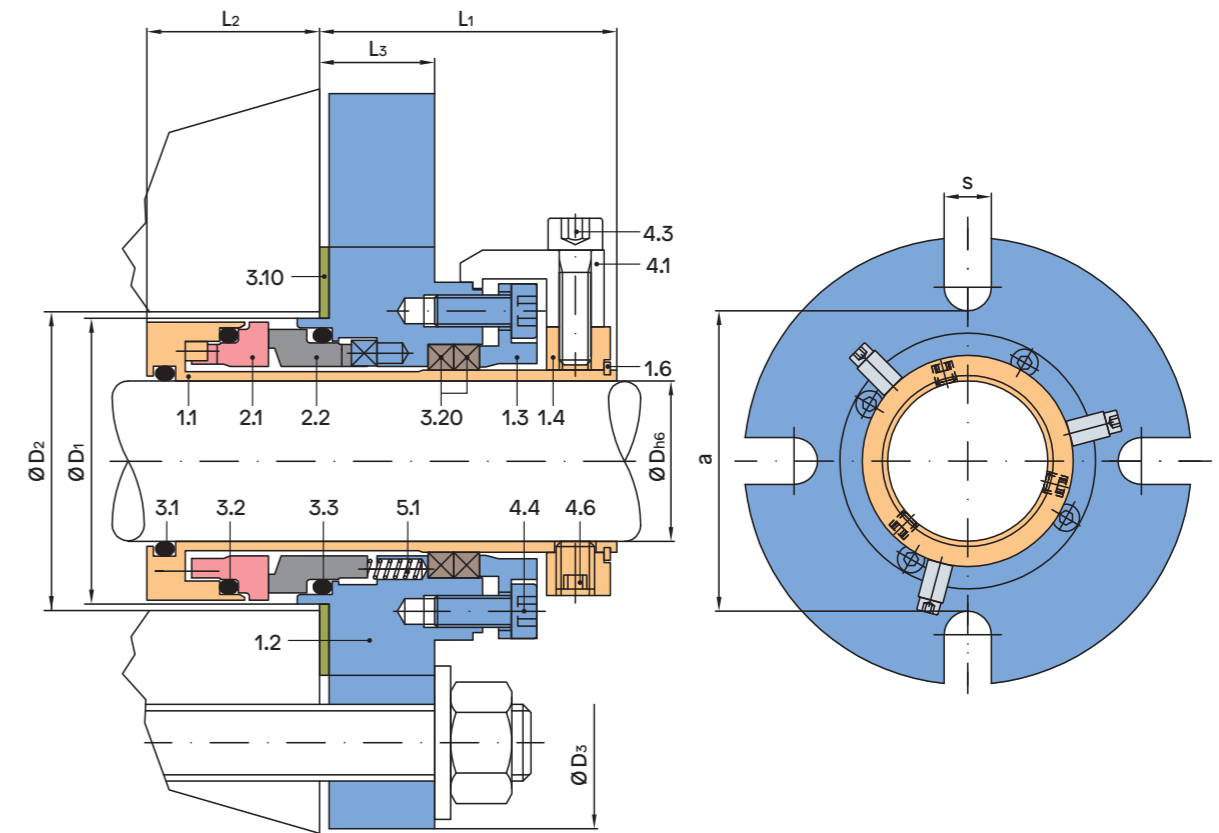
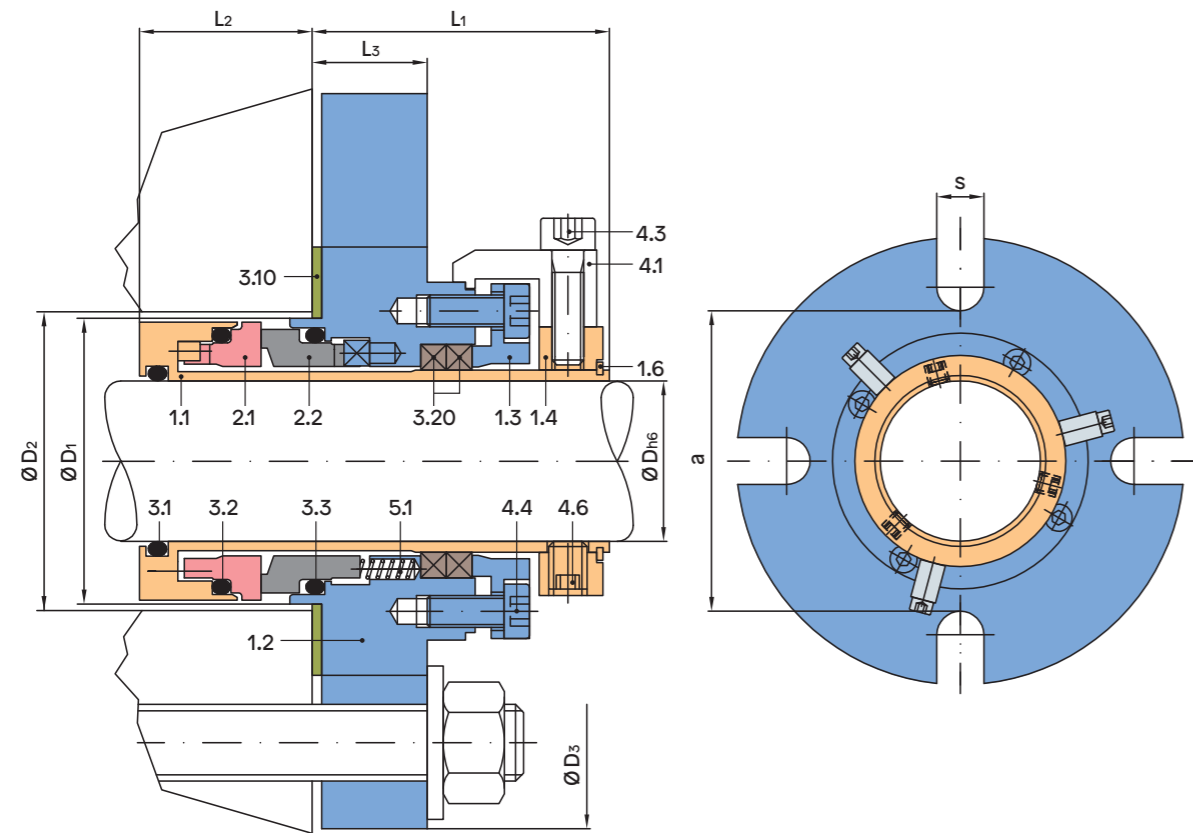

Dimension table Ø 53 – 100 mm

Dimension table Ø 1 – 2 3/4 inches

Dh6	D1	D2 min.	D2 max.	D3	L1	L2	L3	a	s	O-rings DASH no.		
										3.1	3.2	3.3
53	72,7	74,7	84	150	45	28,5	19	92	17,5	138	145	145
55	74,7	76,7	84	150	45	28,5	19	92	17,5	139	146	146
58	77,7	79,7	92	160	45	28,5	19	100	17,5	141	148	148
60	79,7	81,7	92	160	45	28,5	19	100	17,5	142	149	149
63	82,7	84,7	97	165	45	28,5	19	105	17,5	144	150	150
65	84,7	86,7	97	165	45	28,5	19	105	17,5	145	151	151
68	87,7	89,7	112	180	45	28,5	19	120	17,5	148	151	151
70	89,7	91,7	112	180	45	28,5	19	120	17,5	149	152	152
75	102,8	104,8	117	190	50	34	22	125	17,5	234	238	238
80	107,8	109,8	122	190	50	34	22	130	17,5	236	240	240
85	112,8	114,8	129	220	50	34	22	137	21,5	237	242	242
90	117,8	119,8	134	220	50	34	22	142	21,5	239	243	243
95	122,8	124,8	139	220	50	34	22	147	21,5	240	245	245
100	127,8	129,8	144	220	50	34	22	152	21,5	242	246	246

Dh6	D1	D2 min.	D2 max.	D3	L1	L2	L3	a	s	O-rings DASH no.		
										3.1	3.2	3.3
1	1,760	1,839	2,126	4,094	1,772	1,122	0,748	2,441	0,492	120	127	127
1 1/8	1,878	1,957	2,126	4,094	1,772	1,122	0,748	2,441	0,492	122	129	129
1 1/4	2,004	2,083	2,323	4,094	1,772	1,122	0,748	2,638	0,492	124	131	131
1 3/8	2,154	2,233	2,441	4,528	1,772	1,122	0,748	2,756	0,492	126	133	133
1 1/2	2,272	2,351	2,638	4,921	1,772	1,122	0,748	2,953	0,579	128	136	136
1 5/8	2,429	2,508	2,835	5,236	1,772	1,122	0,748	3,150	0,579	131	138	138
1 3/4	2,547	2,626	2,913	5,512	1,772	1,122	0,748	3,228	0,579	133	140	140
1 7/8	2,665	2,744	2,913	5,512	1,772	1,122	0,748	3,228	0,579	135	142	142
2	2,744	2,823	3,110	5,512	1,772	1,122	0,748	3,425	0,579	136	143	143
2 1/8	2,862	2,941	3,307	5,906	1,772	1,122	0,748	3,622	0,689	138	145	145
2 1/4	3,020	3,099	3,622	6,299	1,772	1,122	0,748	3,937	0,689	140	147	147
2 3/8	3,158	3,217	3,622	6,299	1,772	1,122	0,748	3,937	0,689	142	149	149
2 1/2	3,256	3,335	3,819	6,496	1,772	1,122	0,748	4,134	0,689	144	150	150
2 5/8	3,413	3,492	4,409	7,087	1,772	1,122	0,748	4,724	0,689	146	151	151
2 3/4	3,531	3,610	4,409	7,087	1,772	1,122	0,748	4,724	0,689	149	152	152

Safety seal Type 270P



Safety seal Type 301P

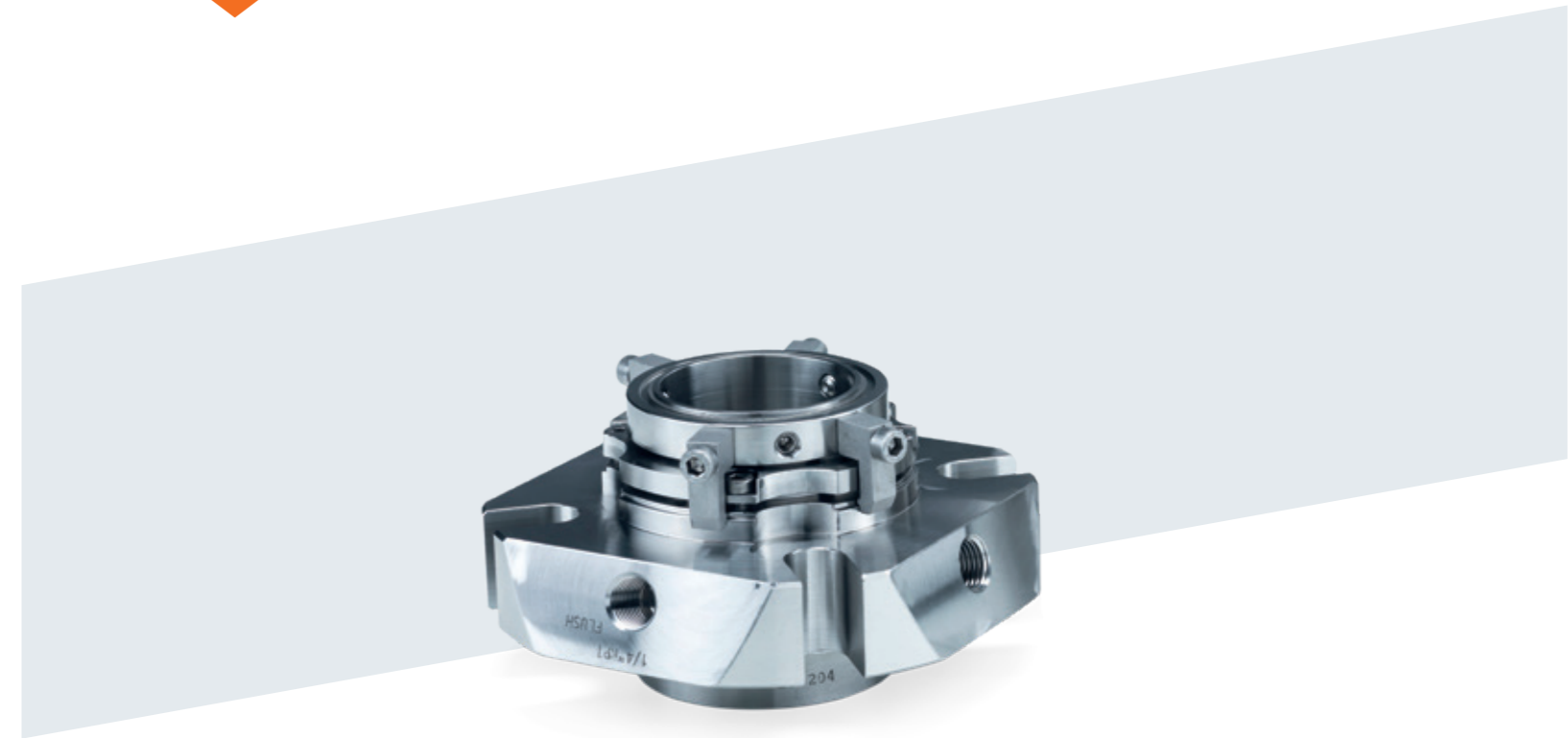
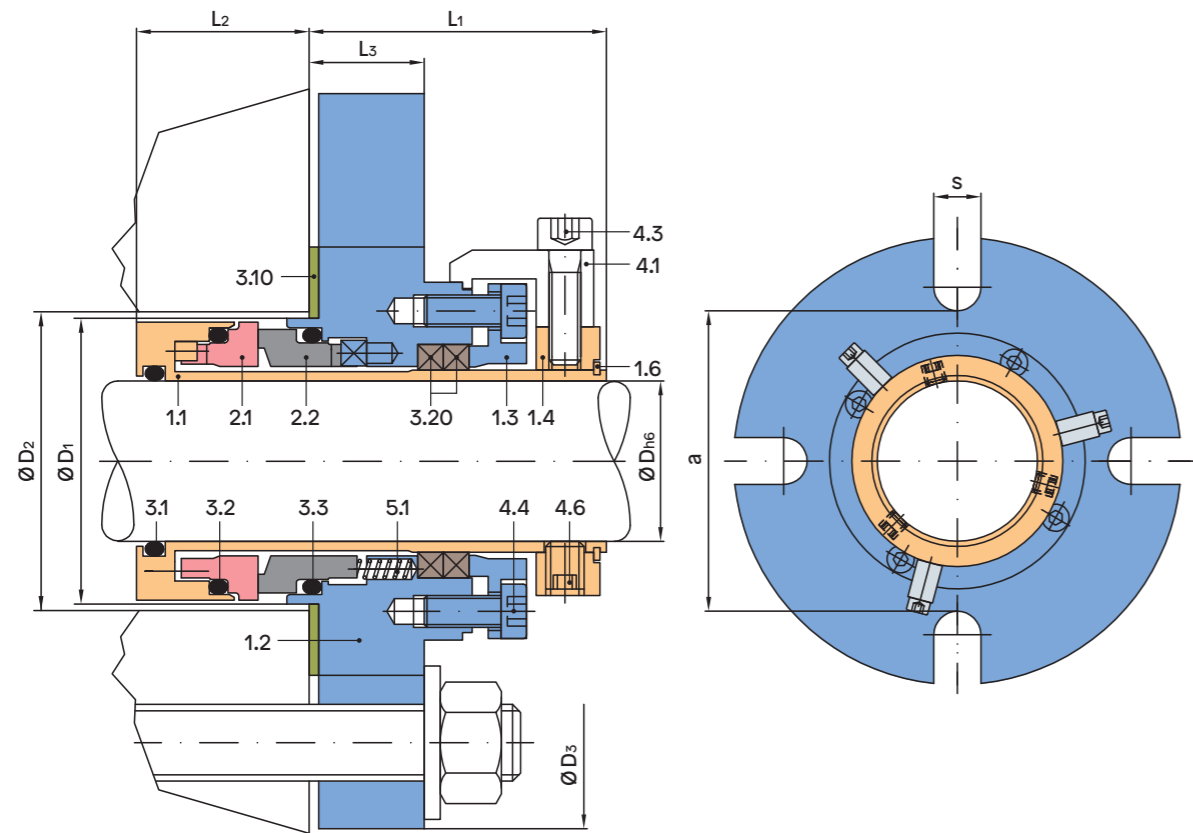

No mechanical seal lasts forever. Even with double seals, no manufacturer can guarantee that the second seal face pair will seal after the first has failed. The „Disaster Bushings“ demanded by the oil industry (API) also offer no protection in case of a leakage. The DEPAC type 301P, conversely, guarantees a high level of process reliability, because in the case of seal damage the integrated packing is simply adjusted to a minimum leakage rate and the mechanical seal can thus remain in service until the next planned standstill. The DEPAC type 301P is the new standard in cartridge-mounted mechanical seals, since expensive production losses and unplanned emergency assignments of fitters can be prevented.

Dimension table Ø 2 7/8 – 4 inches

Dh6	D1	D2 min.	D2 max.	D3	L1	L2	L3	a	s	O-rings DASH no.		
										3.1	3.2	3.3
2 7/8	3,969	4,048	4,606	7,480	1,969	1,339	0,866	4,921	0,689	233	238	238
3	4,047	4,126	4,606	7,480	1,969	1,339	0,866	4,921	0,689	234	238	238
3 1/8	4,244	4,323	4,803	7,480	1,969	1,339	0,866	5,118	0,689	236	240	240
3 1/4	4,362	4,441	5,079	8,661	1,969	1,339	0,866	5,394	0,846	236	241	241
3 3/8	4,441	4,520	5,079	8,661	1,969	1,339	0,866	5,394	0,846	237	242	242
3 1/2	4,638	4,717	5,276	8,661	1,969	1,339	0,866	5,591	0,846	239	243	243
3 5/8	4,717	4,796	5,472	8,661	1,969	1,339	0,866	5,787	0,846	239	244	244
3 3/4	4,835	4,914	5,472	8,661	1,969	1,339	0,866	5,787	0,846	240	245	245
3 7/8	5,031	5,110	5,669	8,661	1,969	1,339	0,866	5,984	0,846	242	246	246
4	5,031	5,110	5,669	8,661	1,969	1,339	0,866	5,984	0,846	242	246	246

Advantages

- Adjustable safety seal
- Stationary design principle
- Ideal for conversions from gland packings to mechanical seals
- Extremely well suited for standardisations
- Cartridge-mounted
- Pressure balanced
- Independent of the direction of rotation
- Multi-springs made of Hastelloy C
- Springs outside the medium
- Gland with 1/4" NPT axial flushing and quenching connection

Safety seal Type 301P

Safety seal Type 301P

Technical specifications

Area of application*

Pressure:	700 mmHg to 28 bar
Temperature:	depending on elastomer
Sliding speed:	up to 35 m/s
Shaft movements:	axial ± 1,0 mm radial ± 0,5 mm

* The maximum specifications for temperature, pressure and sliding speed apply in each case to independent higher operating conditions. However, this does not mean that the seal will function with all extreme conditions at the same time. If in doubt contact DEPAC.

Maße

Shaft diameter:	24 – 160 mm 1" – 6 ¼"
	Special sizes on request

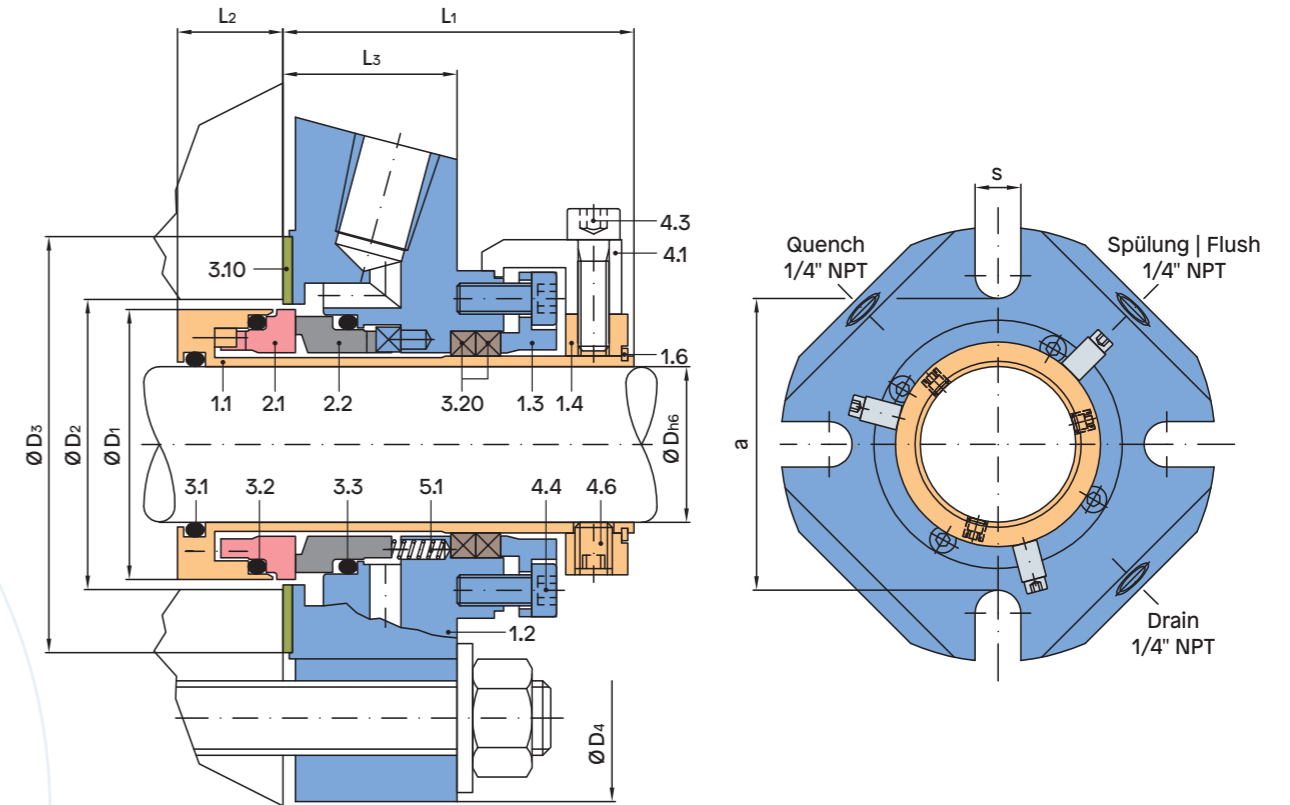
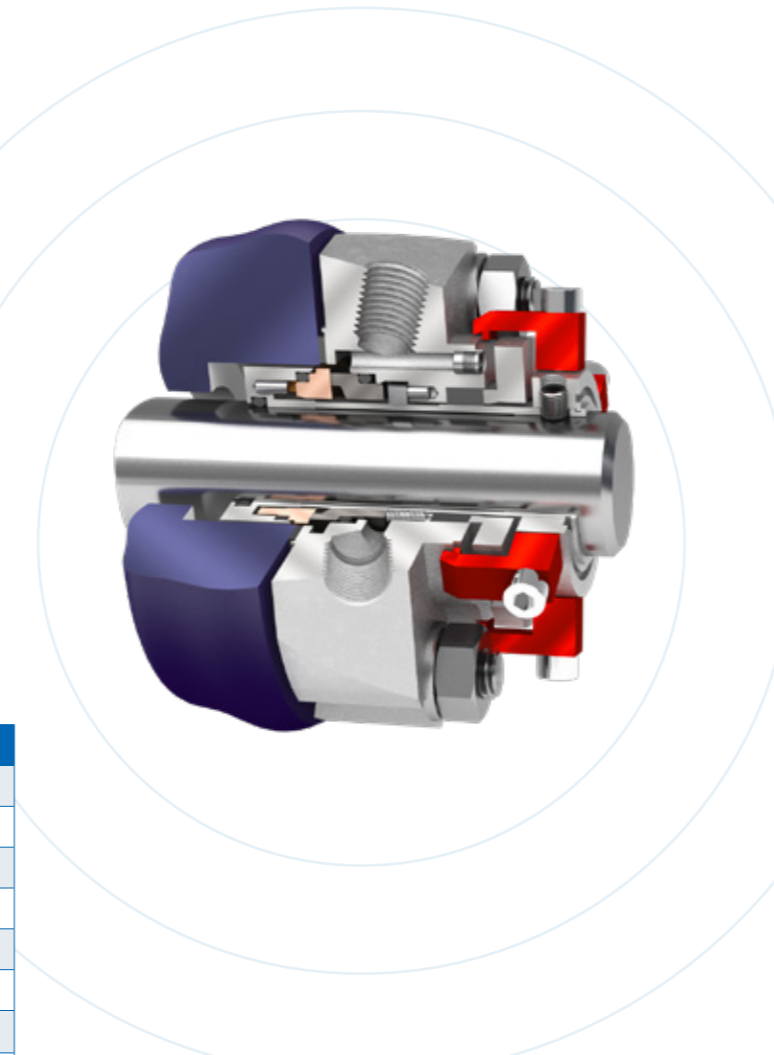

Bill of materials

Position	Beschreibung	Material
1.1	Sleeve	1.4571
1.2	Gland	1.4571
1.3	Packing gland	1.4571
1.4	Adjusting ring	1.4571
1.6	Circlip	1.4310
2.1	Dynamic seal face	SC/SSIC/TC
2.2	Stationary seal face	CA/SC/SSIC/TC
3.1, 3.2, 3.3	O-ring	FKM, EPDM, Kalrez®, PTFE,...
3.10	Flat gasket	Klingersil® C-4300
3.20	Integrated safety packing	Graphit - PTFE Packung DEPAC Type 730
4.1	Centering piece	Al
4.3	Socket screw	A2
4.4	Socket screw	A2
4.6	Threaded pin	A4
5.1	Spring	2.4610

Other materials on request!

Dimension table Ø 24 – 53 mm

Dh6	D1	D2 min.	D2 max.	D3	D4	L1	L2	L3	a	s	O-rings DASH no.		
											3.1	3.2	3.3
24	43,5	45,5	52	60	104	56,5	17	28	62	12,5	120	127	127
25	43,5	45,5	52	60	104	56,5	17	28	62	12,5	120	127	127
28	46,5	48,5	52	60	104	56,5	17	28	62	12,5	122	129	129
30	48,5	50,5	57	65	104	56,5	17	28	67	12,5	123	130	130
32	50	52	57	65	104	56,5	17	28	67	12,5	124	131	131
33	50	52	57	65	104	56,5	17	28	67	12,5	125	131	131
35	53,5	55,5	60	68	115	56,5	17	28	70	12,5	126	133	133
38	56,5	58,5	65	73	125	56,5	17	28	75	14,7	128	136	136
40	58,5	60,5	65	73	125	56,5	17	28	75	14,7	130	137	137
42	60,5	62,5	70	78	133	56,5	17	28	80	14,7	131	138	138
43	61,5	63,5	70	78	133	56,5	17	28	80	14,7	132	138	138
45	63,5	65,5	72	80	140	56,5	17	28	82	14,7	133	140	140
48	66,5	68,5	72	80	140	56,5	17	28	82	14,7	135	142	142
50	68,5	70,5	77	85	140	56,5	17	28	87	14,7	136	143	143
53	71,5	73,5	82	90	150	56,5	17	28	92	17,5	138	145	145

Safety seal Type 301P

Safety seal Type 301P

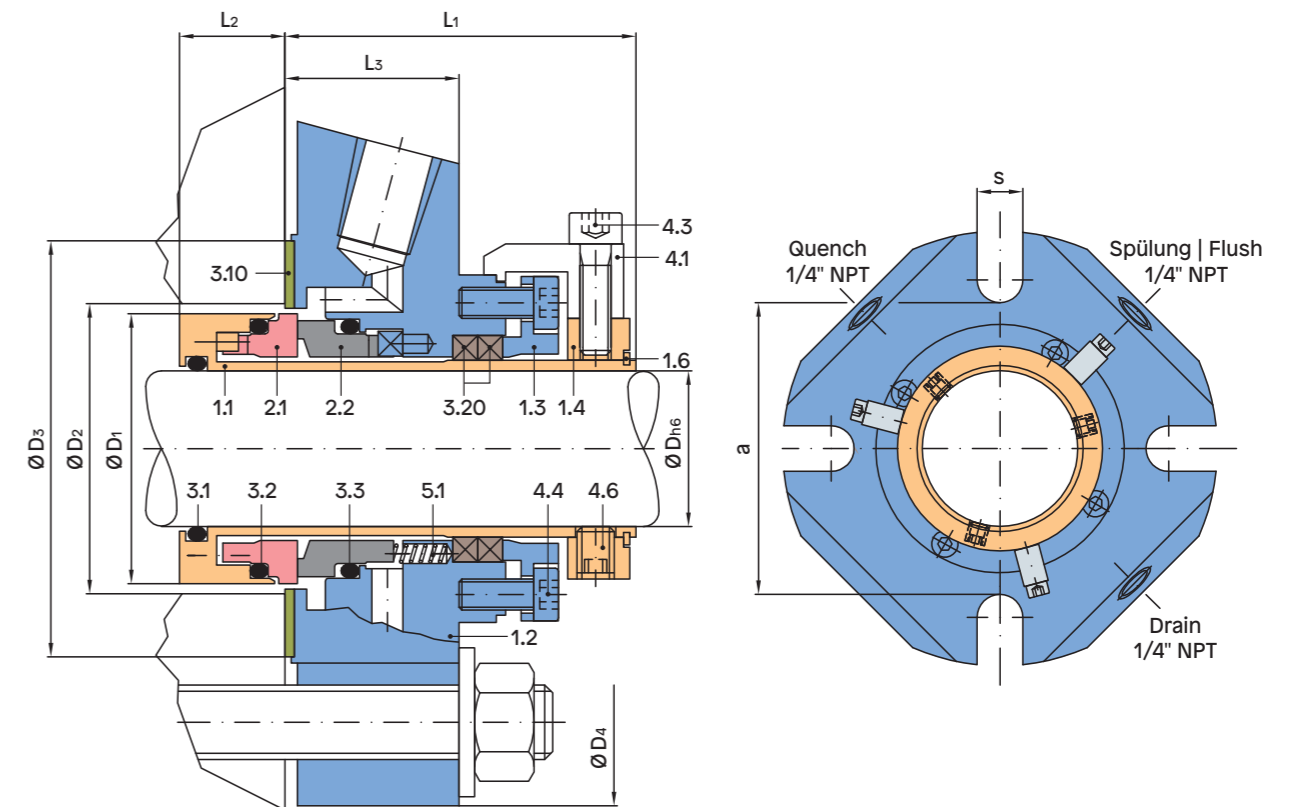
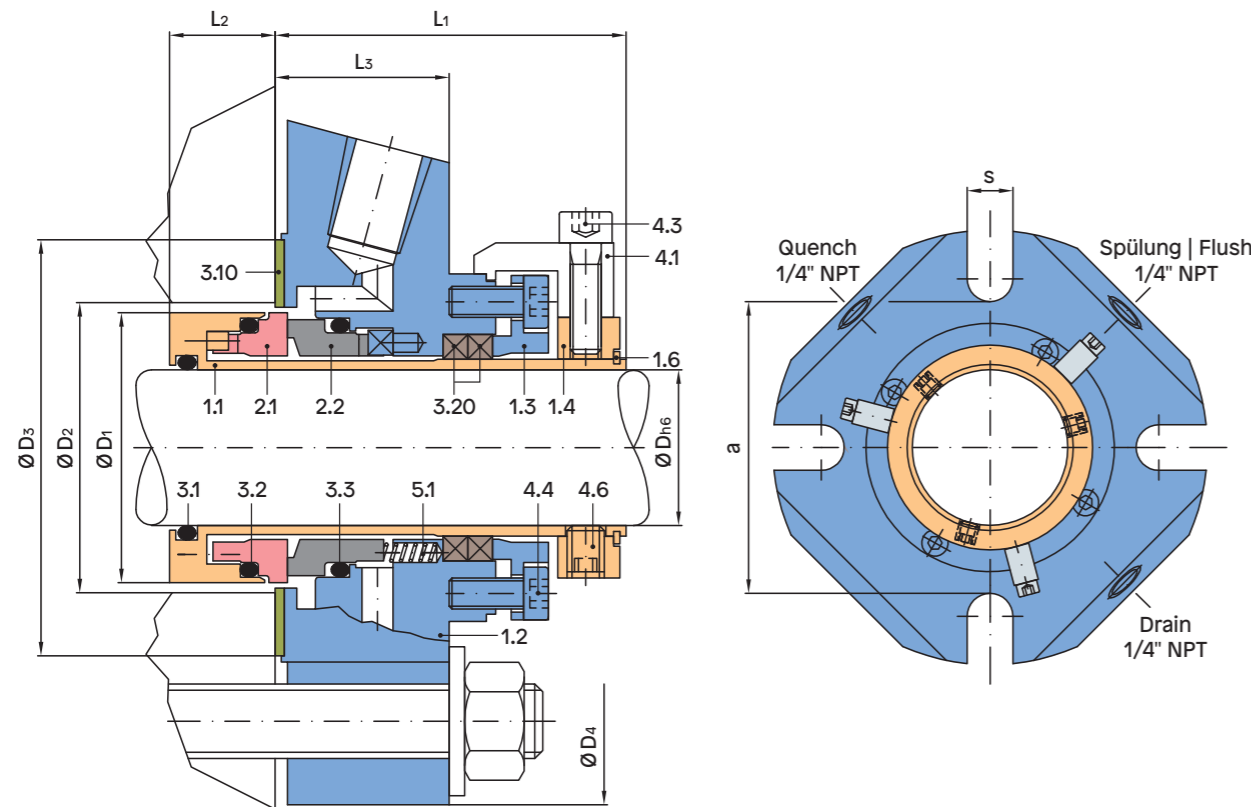

Dimension table $\varnothing 55 - 70$ mm

Dh6	D1	D2 min.	D2 max.	D3	D4	L1	L2	L3	a	s	O-rings DASH no.		
											3.1	3.2	3.3
55	73,5	75,5	82	90	150	56,5	17	28	92	17,5	139	146	146
58	76,5	78,5	90	98	160	56,5	17	28	100	17,5	141	148	148
60	78,5	80,5	90	98	160	56,5	17	28	100	17,5	142	149	149
63	81,5	83,5	95	103	165	56,5	17	28	105	17,5	144	150	150
65	83,5	85,5	95	103	165	56,5	17	28	105	17,5	145	151	151
68	86,5	88,5	110	118	180	56,5	17	28	120	17,5	148	151	151
70	88,5	90,5	110	118	180	56,5	17	28	120	17,5	149	152	152

Dimension table $\varnothing 75 - 115$ mm

Dh6	D1	D2 min.	D2 max.	D3	D4	L1	L2	L3	a	s	O-rings DASH no.		
											3.1	3.2	3.3
75	100	102	115	123	190	61	23	30	125	17,5	234	238	238
80	105	107	120	128	190	61	23	30	130	17,5	236	240	240
85	110	112	127	135	220	61	23	30	137	21,5	237	242	242
90	115	117	132	140	220	61	23	30	142	21,5	239	243	243
95	120	122	137	145	220	61	23	30	147	21,5	240	245	245
100	125	127	142	150	220	61	23	30	152	21,5	242	246	246
105	130	132	147	155	240	61	23	30	157	21,5	244	248	248
110	135	137	152	160	240	61	23	30	162	21,5	245	250	250
115	140	142	157	165	240	61	23	30	167	21,5	247	251	251

Safety seal Type 301P

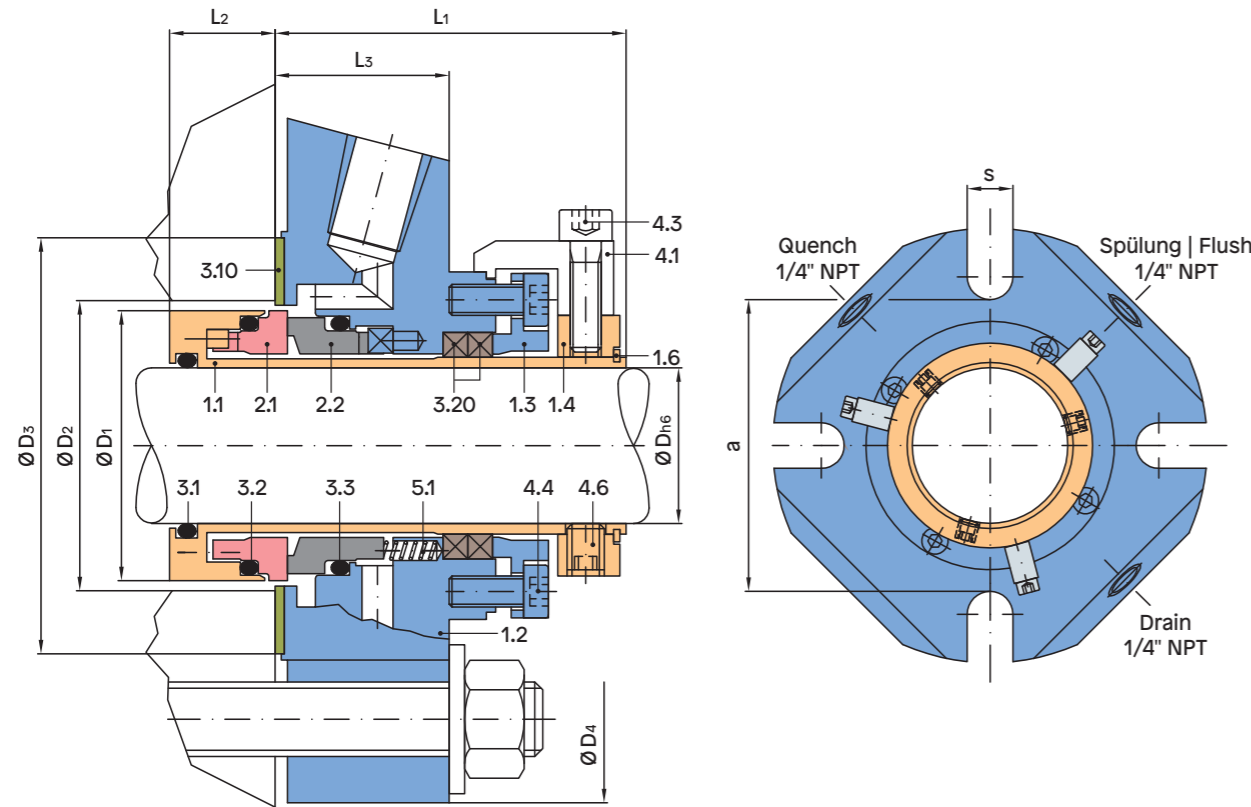

Safety seal Type 301P

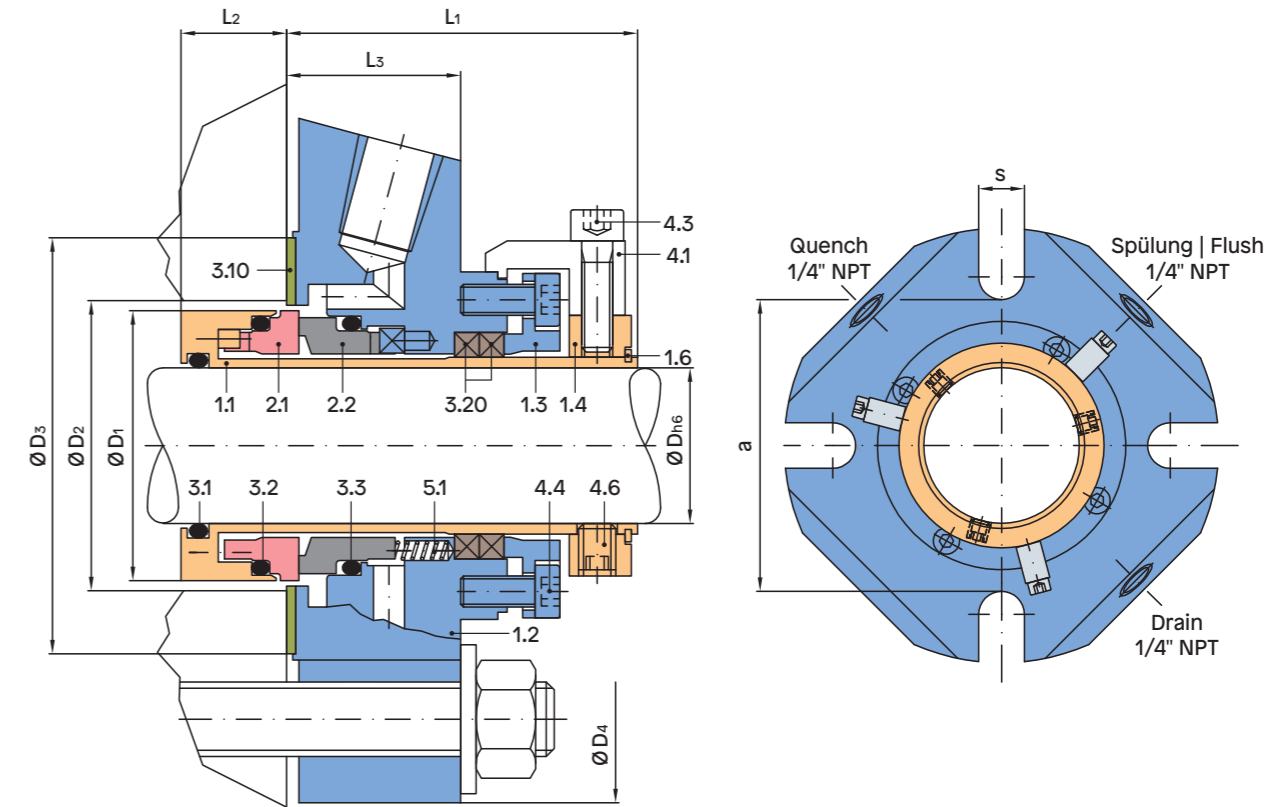

Dimension table Ø 120 – 160 mm

Dh6	D1	D2 min.	D2 max.	D3	D4	L1	L2	L3	a	s	O-rings DASH no.		
											3.1	3.2	3.3
120	145	147	162	170	240	61	23	30	172	21,5	248	253	253
125	150	152	167	175	260	61	23	30	177	21,5	250	254	254
130	155	157	172	180	260	61	23	30	182	21,5	251	256	256
135	160	162	177	185	260	61	23	30	187	21,5	253	258	258
140	165	167	182	190	260	61	23	30	192	21,5	255	258	258
145	170	172	187	195	280	61	23	30	197	21,5	256	259	259
150	175	177	192	200	280	61	23	30	202	21,5	258	260	260
155	180	182	197	205	280	61	23	30	207	21,5	259	261	261
160	185	187	202	210	280	61	23	30	212	21,5	260	261	261

Dimension table Ø 1 – 2 3/4 inches

Dh6	D1	D2 min.	D2 max.	D3	D4	L1	L2	L3	a	s	O-rings DASH no.		
											3.1	3.2	3.3
1	1,713	1,791	2,047	2,362	4,094	2,224	0,669	1,102	2,441	0,492	120	127	127
1 1/8	1,831	1,909	2,047	2,362	4,094	2,224	0,669	1,102	2,441	0,492	122	129	129
1 1/4	1,969	2,047	2,244	2,559	4,094	2,224	0,669	1,102	2,638	0,492	124	131	131
1 3/8	2,106	2,185	2,362	2,677	4,528	2,224	0,669	1,102	2,756	0,492	126	133	133
1 1/2	2,224	2,303	2,559	2,874	4,921	2,224	0,669	1,102	2,953	0,579	128	136	136
1 5/8	2,421	2,500	2,756	3,071	5,236	2,224	0,669	1,102	3,150	0,579	131	138	138
1 3/4	2,500	2,579	2,835	3,150	5,512	2,224	0,669	1,102	3,228	0,579	133	140	140
1 7/8	2,618	2,697	2,835	3,150	5,512	2,224	0,669	1,102	3,228	0,579	135	142	142
2	2,697	2,776	3,031	3,346	5,512	2,224	0,669	1,102	3,425	0,579	136	143	143
2 1/8	2,815	2,894	3,228	3,543	5,906	2,224	0,669	1,102	3,622	0,689	138	145	145
2 1/4	2,972	3,051	3,543	3,858	6,299	2,224	0,669	1,102	3,937	0,689	140	147	147
2 3/8	3,091	3,169	3,543	3,858	6,299	2,224	0,669	1,102	3,937	0,689	142	149	149
2 1/2	3,209	3,287	3,740	4,055	6,496	2,224	0,669	1,102	4,134	0,689	144	150	150
2 5/8	3,366	3,445	4,331	4,646	7,087	2,224	0,669	1,102	4,724	0,689	146	151	151
2 3/4	3,484	3,563	4,331	4,646	7,087	2,224	0,669	1,102	4,724	0,689	149	152	152

Safety seal Type 301P

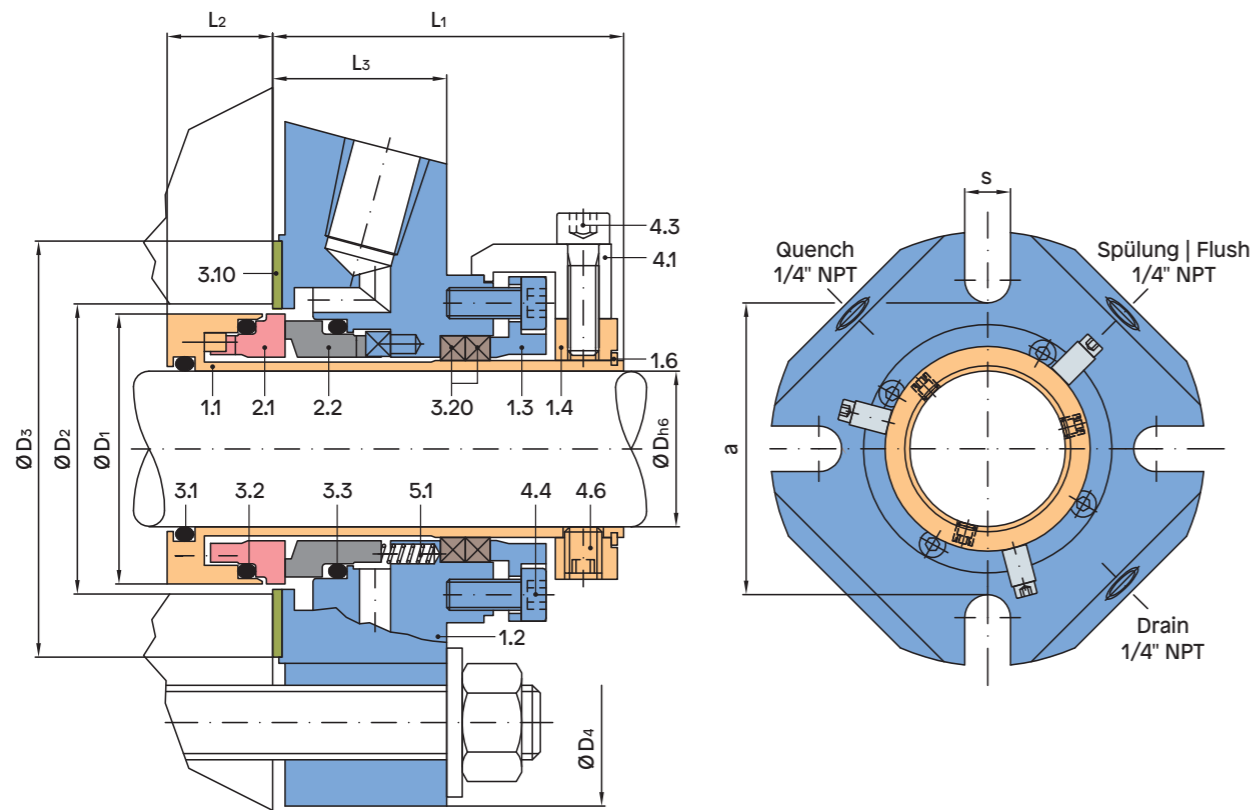

Safety seal Type 301P

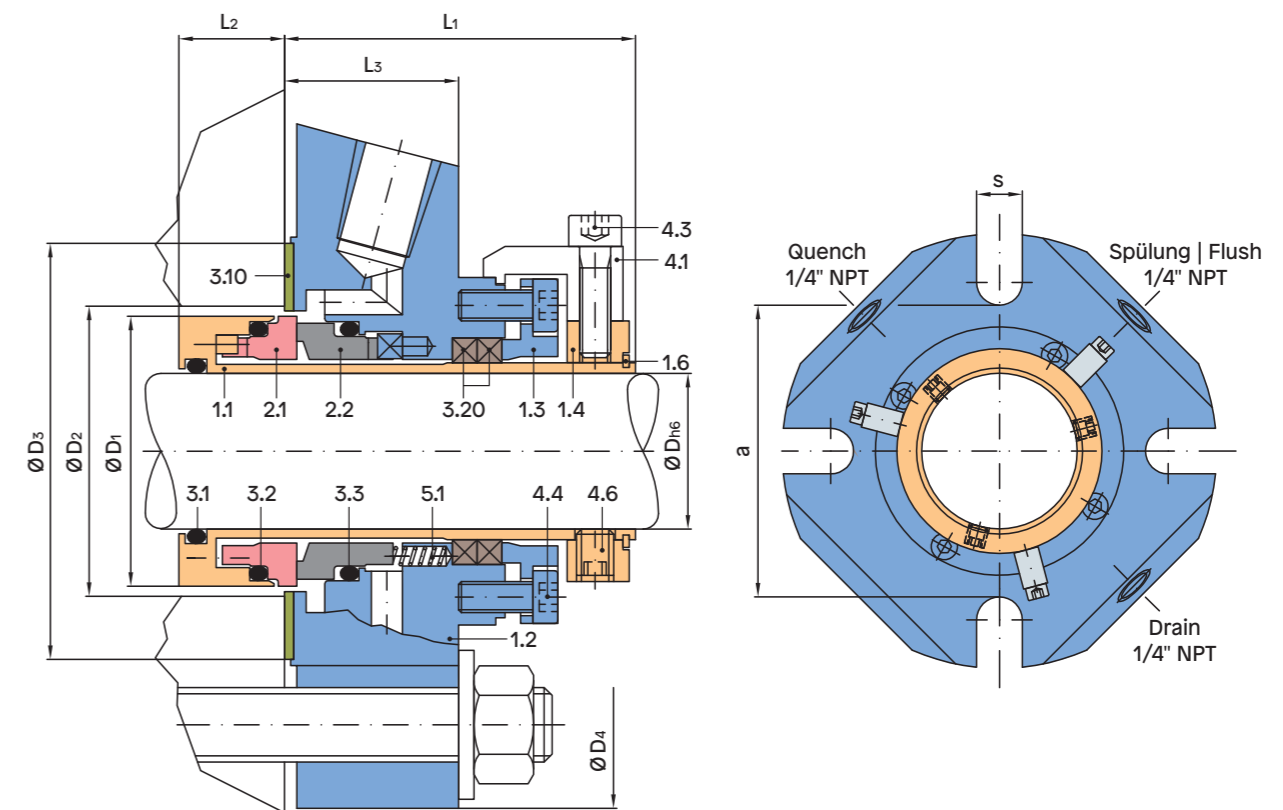

Dimension table $\varnothing 2\frac{7}{8} - 5$ inches

Dh6	D1	D2 min.	D2 max.	D3	D4	L1	L2	L3	a	s	O-rings DASH no.		
											3.1	3.2	3.3
2 7/8	3,858	3,937	4,528	4,843	7,480	2,402	0,906	1,181	4,921	0,689	233	238	238
3	3,937	4,016	4,528	4,843	7,480	2,402	0,906	1,181	4,921	0,689	234	238	238
3 1/8	4,134	4,213	4,724	5,039	7,480	2,402	0,906	1,181	5,118	0,689	236	240	240
3 1/4	4,252	4,331	5,000	5,315	8,661	2,402	0,906	1,181	5,394	0,846	236	241	241
3 3/8	4,331	4,409	5,000	5,315	8,661	2,402	0,906	1,181	5,394	0,846	237	242	242
3 1/2	4,528	4,606	5,197	5,512	8,661	2,402	0,906	1,181	5,591	0,846	239	243	243
3 5/8	4,606	4,685	5,394	5,709	8,661	2,402	0,906	1,181	5,787	0,846	239	244	244
3 3/4	4,724	4,803	5,394	5,709	8,661	2,402	0,906	1,181	5,787	0,846	240	245	245
3 7/8	4,921	5,000	5,591	5,906	8,661	2,402	0,906	1,181	5,984	0,846	242	246	246
4	4,921	5,000	5,591	5,906	8,661	2,402	0,906	1,181	5,984	0,846	242	246	246
4 1/8	5,118	5,197	5,197	6,102	9,449	2,402	0,906	1,181	6,181	0,846	244	248	248
4 1/4	5,315	5,394	5,394	6,299	9,449	2,402	0,906	1,181	6,378	0,846	245	250	250
4 1/2	5,512	5,591	5,591	6,496	9,449	2,402	0,906	1,181	6,575	0,846	247	251	251
4 3/4	5,709	5,787	5,787	6,693	9,449	2,402	0,906	1,181	6,772	0,846	248	253	253
5	6,102	6,181	6,181	7,087	10,236	2,402	0,906	1,181	7,165	0,846	251	256	256

Dimension table $\varnothing 5\frac{1}{4} - 6\frac{1}{4}$ inches

Dh6	D1	D2 min.	D2 max.	D3	D4	L1	L2	L3	a	s	O-rings DASH no.		
											3.1	3.2	3.3
5 1/4	6,299	6,378	6,378	7,283	10,236	2,402	0,906	1,181	7,362	0,846	253	258	258
5 1/2	6,496	6,575	6,575	7,480	10,236	2,402	0,906	1,181	7,559	0,846	255	258	258
5 3/4	6,693	6,772	6,772	7,677	11,024	2,402	0,906	1,181	7,756	0,846	256	259	259
6	7,087	7,165	7,165	8,071	11,024	2,402	0,906	1,181	8,150	0,846	259	261	261
6 1/4	7,283	7,362	7,362	8,268	11,024	2,402	0,906	1,181	8,346	0,846	260	261	261

Notes

Lined area for taking notes, consisting of horizontal lines spaced evenly down the page.



Mechanical seals
Packings
Hydraulic seals
Workshop
Comtec

DEPAC Anstalt
Wirtschaftspark 44, FL-9492 Eschen
T +423 373 9700, F +423 373 9719
office@depac-fl.com, www.depac.at

Your authorized DEPAC dealer:

E200836